



Collocated at  **OCX<sup>26</sup>** OPEN COMMUNITY  
EXPERIENCE

# Aveiro Living Lab: A Communication, Sensing, and Computing Platform for Smart-Cities

Duarte Raposo, Research Assistant  
Instituto de Telecomunicações, Portugal



# Agenda

- The Aveiro Living Lab
  - Vision
  - A Smart City and Open Lab
- Research Domains, Technologies
  - Network, V2X, 5G
  - Cloud, Edge, SDV
- Services and Use Cases
- Final Remarks

# The NAP Team

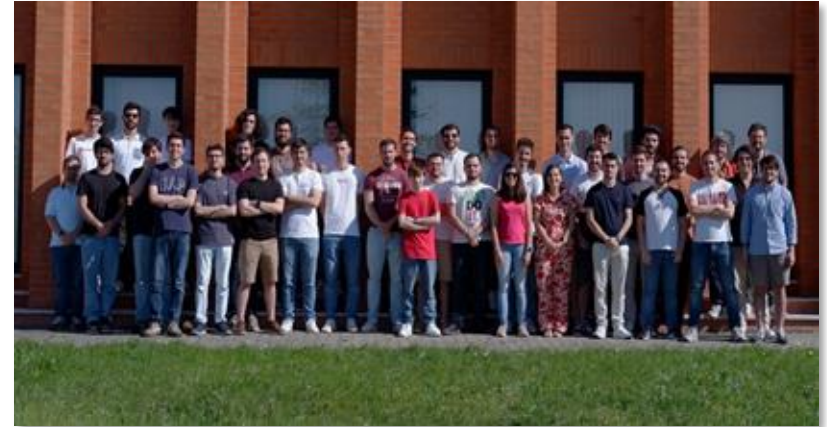
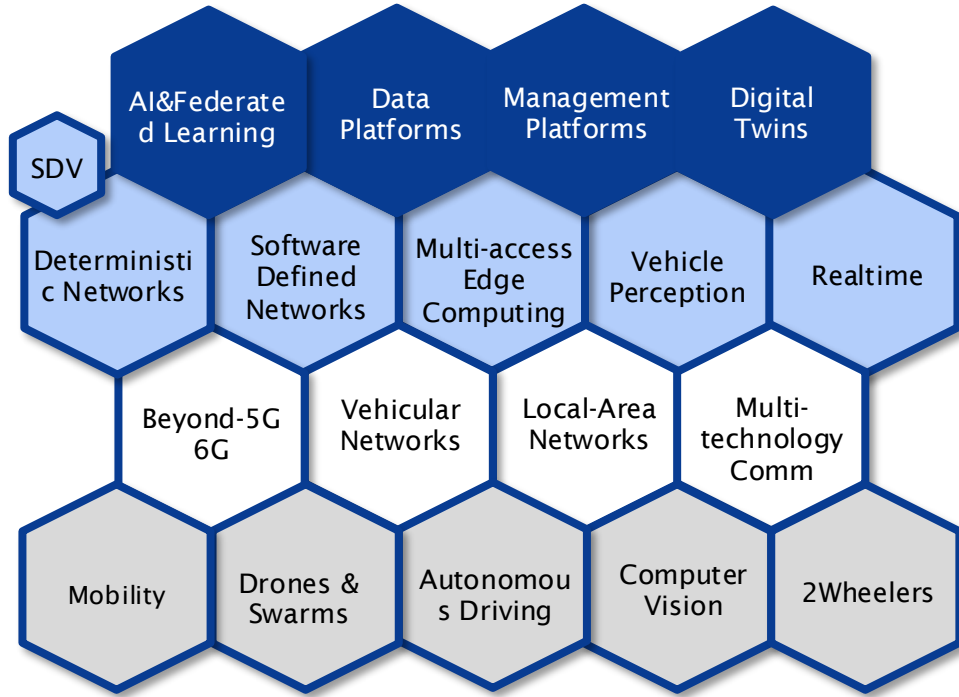

The **Network Applications and Protocols (NAP)** team



# Aveiro Living Lab

# Rethinking Smart Cities: Beyond Software

- Smart Cities: What not to do?
  - So far, the concept of a smart city has been approached through a model of software and data integration, which has slowed down its implementation:
    - **How many smart cities do we currently have in Europe?**
    - How many solutions from one city can be **transferred to another?**
    - In our view, there is no model or ecosystem here that **allows the concept to scale in any meaningful way...**
  - However, we can observe some different examples, such as the city of Xiong'an in China, which is being designed from scratch:
    - Smart cities must have their **own dedicated network and sensing infrastructure** that can be shared;
    - This sensing and network infrastructure can enable a new set of services that can be transferred from city to city **through the standardization**;
      - The same camera can be used both for smart parking and for road safety, by different services;



Xiong'an Smart City in China

# Aveiro Living Lab

- Initially funded through the Institute of Telecommunications' own investment, and later co-financed with the Aveiro City Council under the Urban Innovative Actions (UIA) Programme (€6.1M).
  - An infrastructure deployed at the scale of the city of Aveiro, interconnecting **44 processing and sensing nodes** through 16 km of fiber optics and wireless communications:
    - The communication technologies include **private 5G networks** (N77 band, authorized by ANACOM), **vehicular networks**, and **satellite communications**
    - The infrastructure is designed to support multiple applications by enabling the sharing of computational and sensing resources, thereby reducing both **CapEx** and **OpEx**.
  - It is built to allow the deployment and management of services in a **cloud-like platform model**.
  - The network is managed, maintained, and continuously improved by IT



# Smart Lamp Post and Wall Boxes



City Infrastructure



[aveiro-living-lab.it.pt](http://aveiro-living-lab.it.pt)

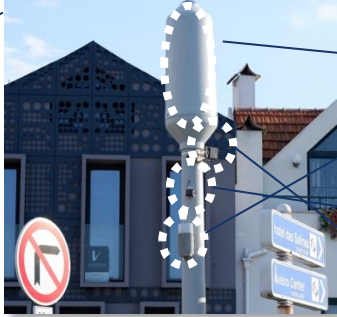

V2X, WiFi,  
Private 5G

Processing on  
the Edge

Video Cameras

Radar

Lidar





# Research Domains and Technologies in the Living Lab

# Network

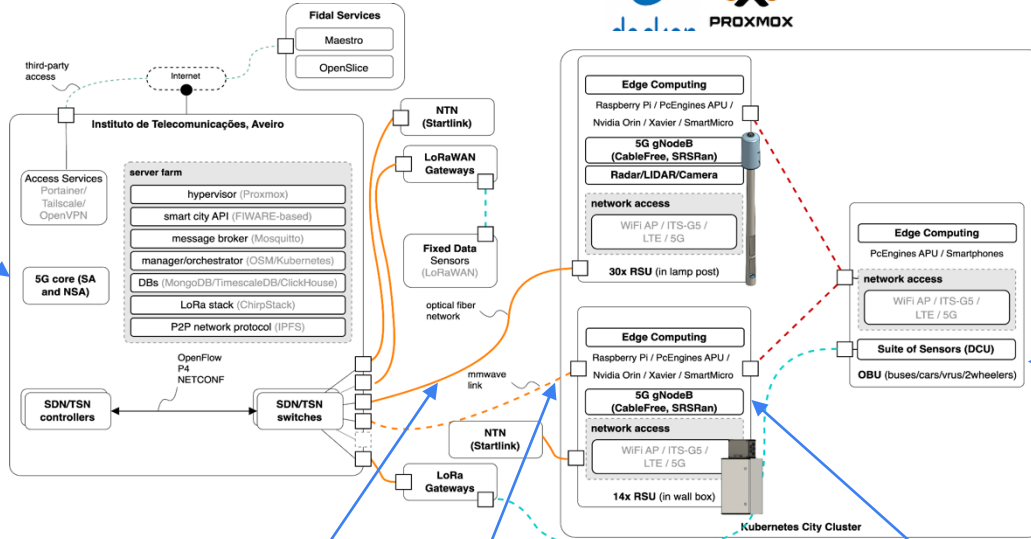
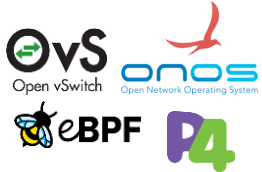

Copyright© Eclipse Foundation AISBL and contributors. Made available under CC-BY-SA 4.0 International.

# Network

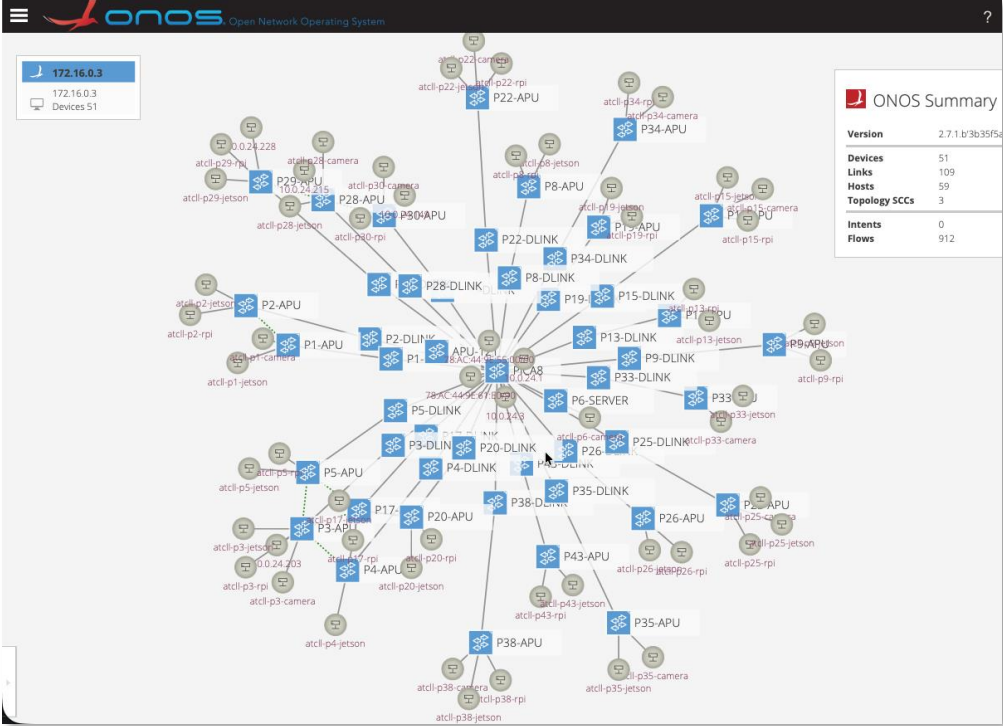

ONOS network perspective

# Orchestration and Data Platform

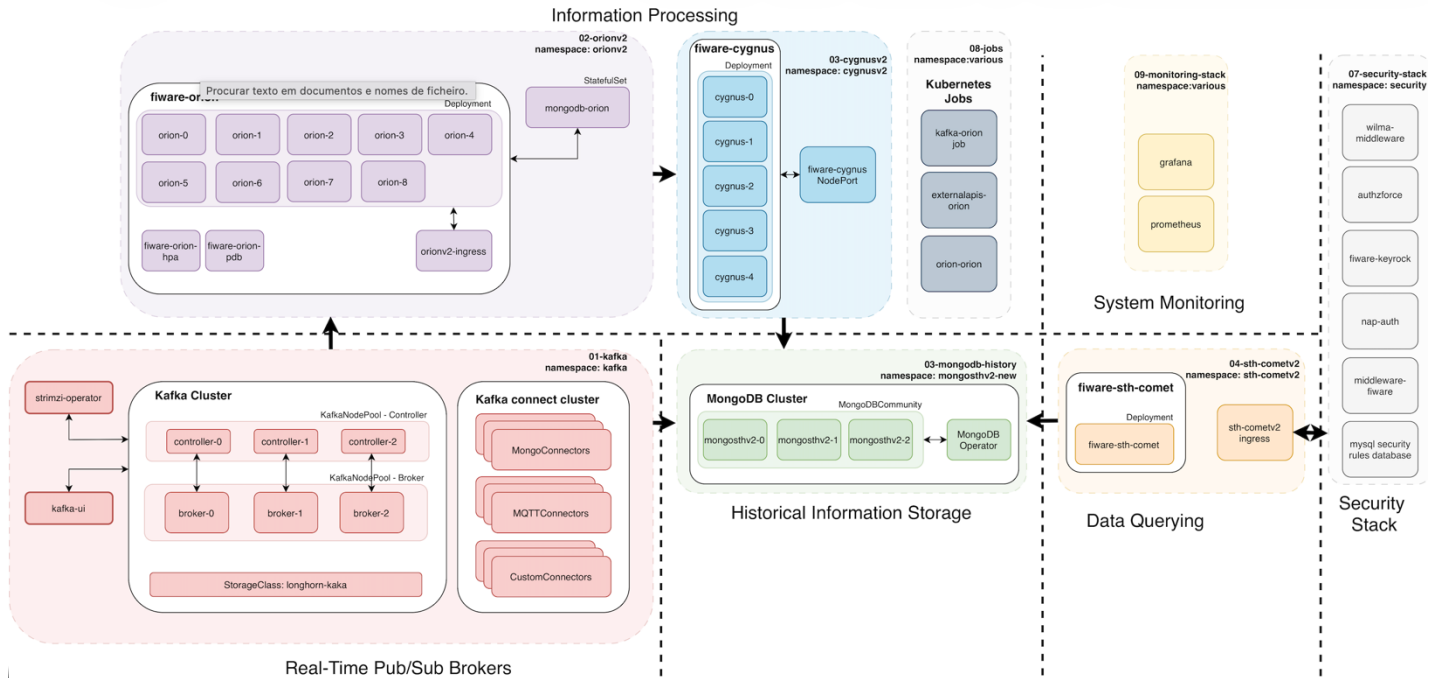

# Autonomous Mobility, UAV and Rovers

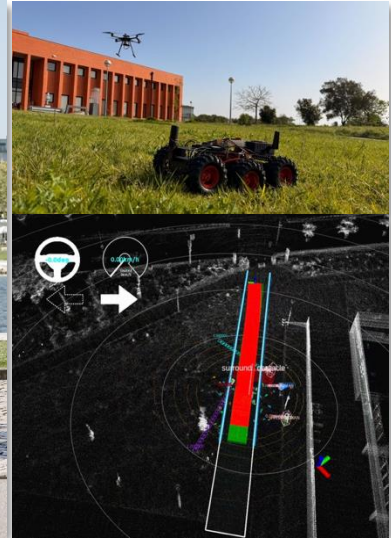
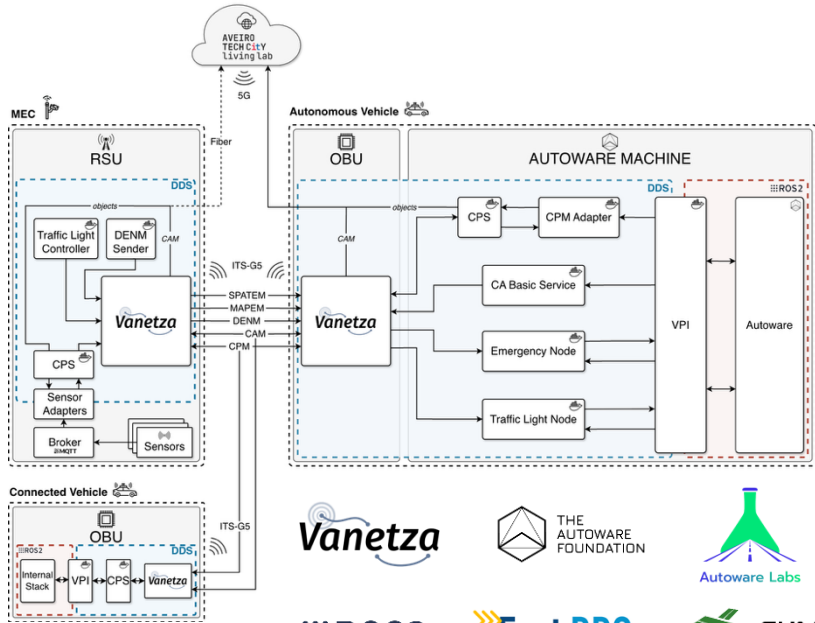



# Services and Use Cases

# Autonomous Mobility



Navya bus with ITS-G5 and V2X interacting with the infrastructure with a virtual semaphore

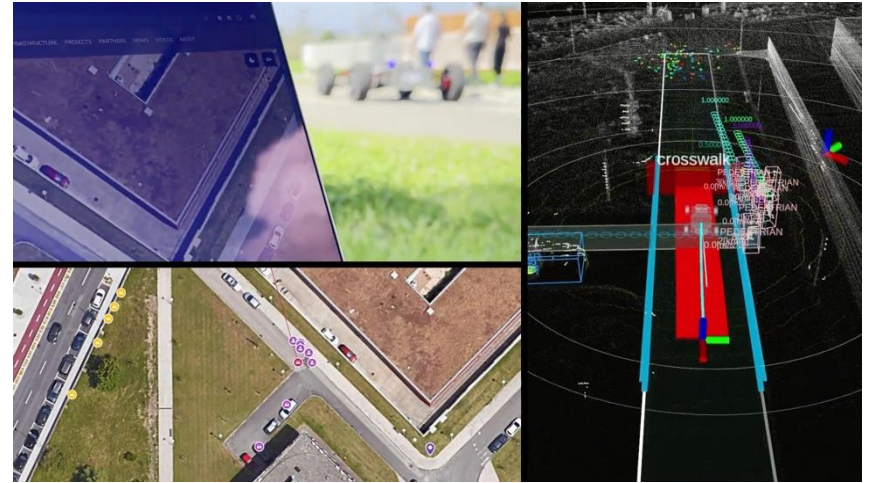

Vision and perception of the autonomous vehicle

# Live Mode



Live View of the web application, objects are detected in real-time

# Computer Vision

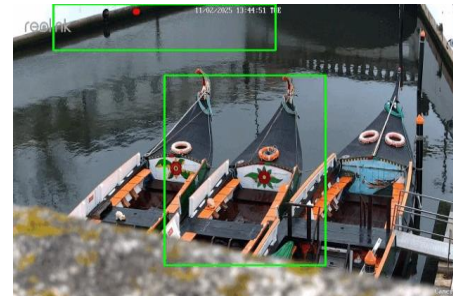
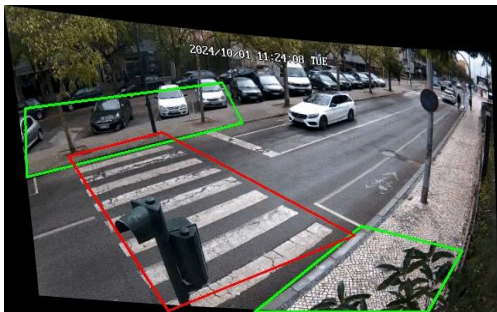
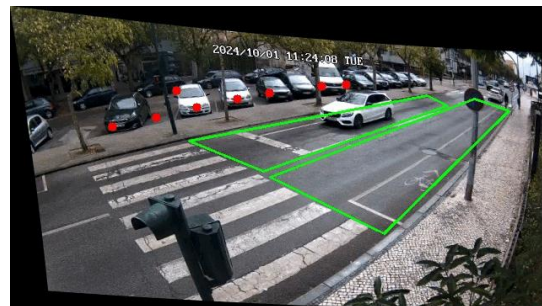

# Monitoring Platform

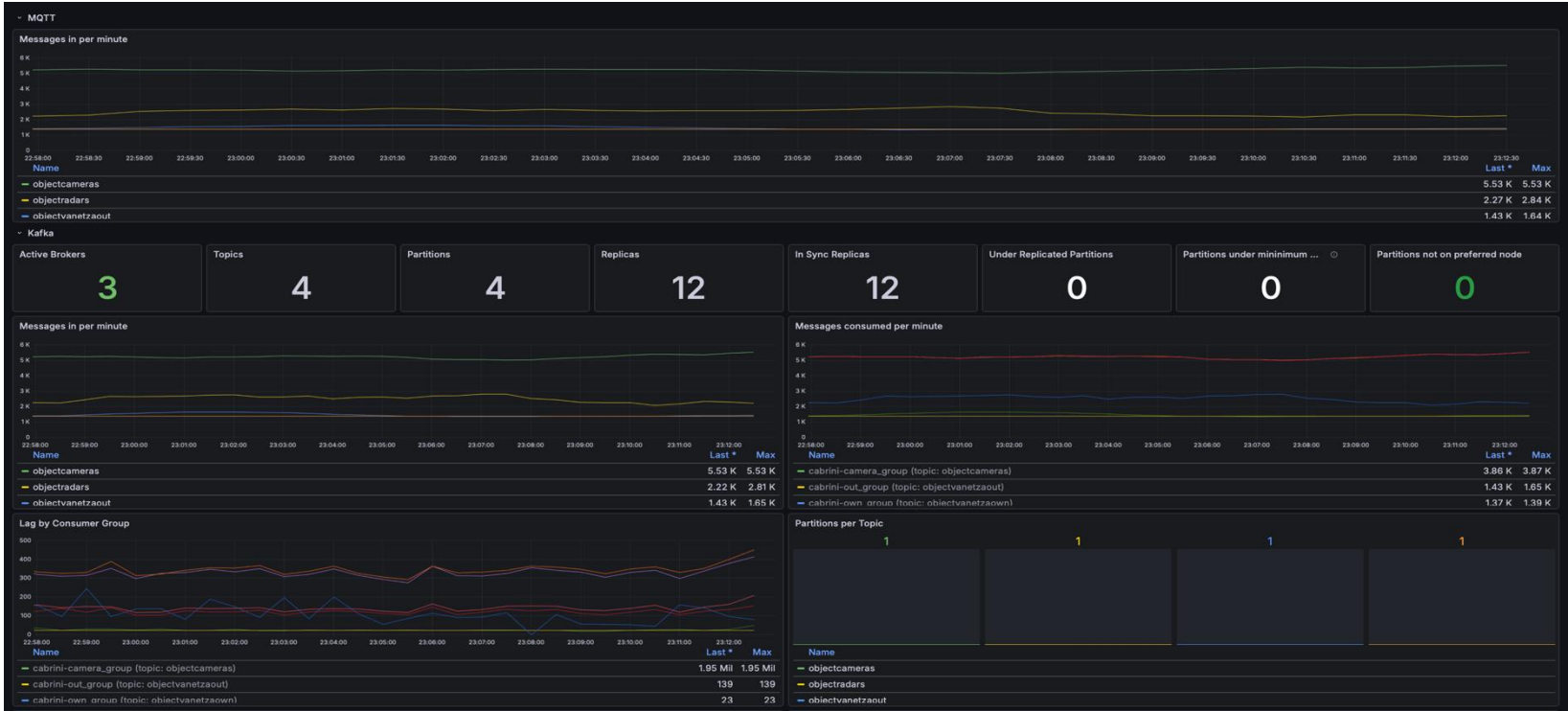

# Smart Parking and Mobility

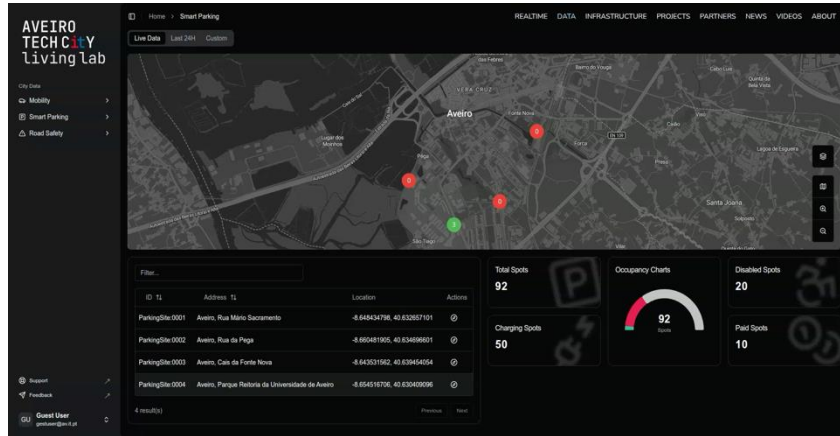

Smart-parking view

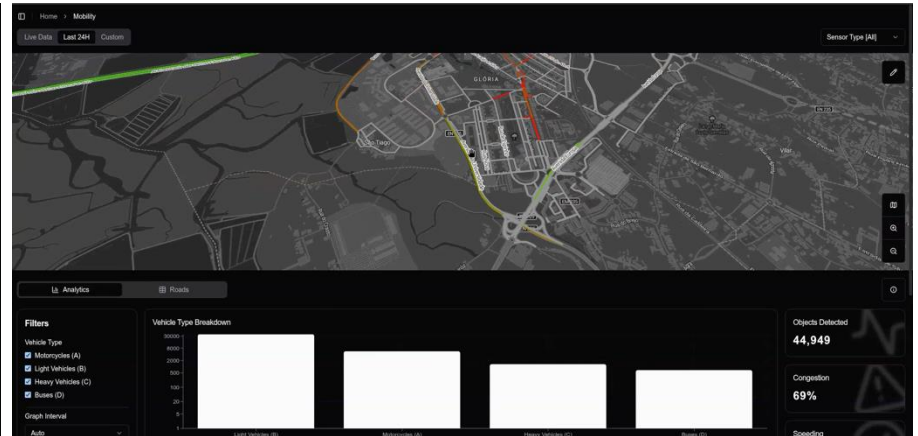

Mobility data collected by the sensors or by V2X

# Safety and SmartCrossWalk

Normal day

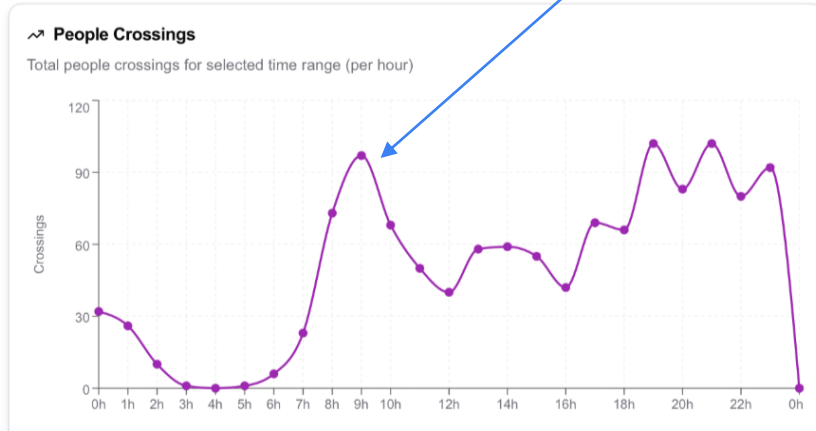

University night event

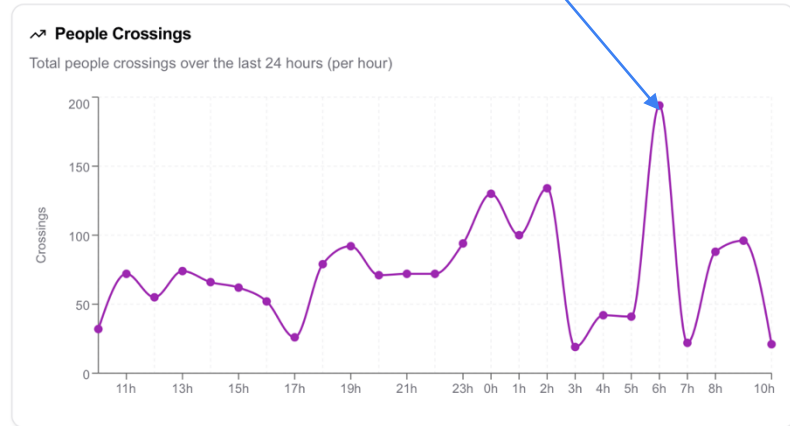

# Integration with AI

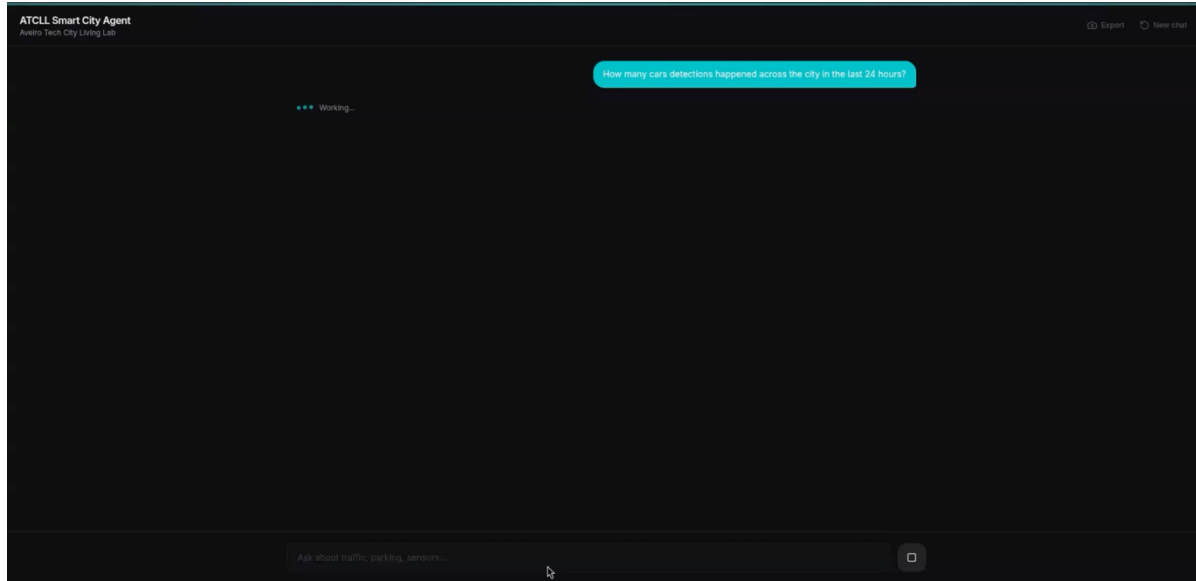

An LLM that could interact with the city data



# Final Remarks

# Final Remarks

- The Aveiro Living Lab is a unique testbed, integrating different sensing technologies and platforms:
  - Future smart cities need to have their **own sensing and communication infrastructure**;
  - The Living Lab can be used to create a more efficient model for monetizing urban services and to mitigate the **high CAPEX and OPEX costs** associated with this type of infrastructure;
  - In our view, this approach is superior to the traditional model of **one supplier → one solution → repeated hardware**;

**YES, smart-cities could be build using open-source!!!**



**OCR**

**OPEN COMMUNITY  
FOR RESEARCH**

**Thank you**

[dmgraposo@av.it.pt](mailto:dmgraposo@av.it.pt)